

# Vehicle Standards Guide 18 (VSG-18)

## Low friction plates on fifth wheels and skid plates

Revised December 2024

This guide provides information for operators, manufacturers and installers about the installation and compliance requirements of low friction plates (LFPs).

### Introduction

Tow couplings fitted to heavy vehicles are critical safety components due to the role they play in keeping a trailer securely connected to the towing vehicle. Because of this, there are stringent strength, design and other standards that apply to couplings and which are set out in the applicable ADR 62/.. *Mechanical Connections between Vehicles* and Australian Standards.

Due to the specific design and nature of a coupling, it is subject to increased wear from friction between the two contacting surfaces. To limit wear and increase the performance of the coupling, grease is traditionally applied on each surface. Instead of using grease, some vehicle operators use an LFP which involves affixing a plate made from synthetic materials either to the fifth wheel or to the skid plate.

While using LFPs is an acceptable alternative to grease, it is important to note that unauthorised modifications or incorrect fitting can have serious impacts on the integrity, function and safety of a coupling.

This guide provides information for operators, LFP manufacturers and installers about the NHVR's requirements for fitting LFPs so that the coupling continues to comply with ADR62/.. and the relevant Australian Standards.

### Information for operators

Operators who decide to fit LFPs can either obtain a fifth wheel designed by the original component manufacturer (OCM) or may choose to modify an existing fifth wheel to accommodate an aftermarket LFP.

LFPs are typically produced specifically for particular makes and models of fifth wheel and it is important to match the correct LFP to the intended fifth wheel.

**Note:** Where a tow coupling is modified, the modified coupling must comply with ADR 62/.. regardless of the vehicle's date of manufacture.

### Coupling manufactured with Low Friction Plate or Low Friction Plate option

Where the fifth wheel and LFP are sourced directly from the OCM, the fifth wheel will have been specifically designed and manufactured to accommodate an LFP.

Installing or replacing an LFP manufactured by the OCM on a coupling designed by the OCM for such an LFP is acceptable providing the installation is carried out in accordance with the OCM specifications.

Drilling holes in order to install an optional OCM LFP is permitted so long as this is part of the OCM's installation instructions and the instructions are complied with.

### Third party supplied Low Friction Plate

Where an LFP that was not manufactured by the OCM (an aftermarket LFP) is being installed, there are a number of requirements that must be met to ensure the ongoing safety and integrity of the coupling.

If the fifth wheel was designed to use an LFP, the OCM's part may be replaced by an aftermarket LFP provided the OCM installation instructions are followed.

However, if the fifth wheel has not been designed to use an LFP, the LFP manufacturer is responsible for verifying that once modified, these components will continue to comply with safety requirements of ADR 62/.. and relevant Australian Standards.

The manufacturer of a third party LFP is required to publish a declaration of continued compliance and include the following information:

- the make and model of the fifth wheel or types of trailers to which it can be fitted
- the approved drilling pattern (if applicable)
- comprehensive installation instructions.

Operators should ensure they only use third party LFPs where this information is provided and follow all installation and maintenance instructions included to ensure their coupling remains safe and compliant.

**Note:** Any modification or use of a third-party product, not supported by the OCM, may adversely impact the manufacturer's warranty.

## Installation requirements

Installation of LFPs to the fifth wheel is achieved by bolting a replaceable plate or pad directly to the flat upper surface of the fifth wheel. Before installing an LFP to a fifth wheel, ensure the following are considered:

- check the upper surface of the fifth wheel for any signs of damage or cracking and ensure the surface is thoroughly cleaned
- for an LFP manufactured by the OCM, confirm that the LFP has been designed for the make and model of fifth wheel it is being fitted to
- for an LFP manufactured by a third party provider, confirm that the LFP has a declaration of continued compliance and has been designed for the make and model of fifth wheel it is being fitted to
- the drilling of any bolt holes are only located in areas detailed in the LFP installation instructions
- the LFP is bolted to the fifth wheel in accordance with the LFP installation instructions and only using hardware provided with the LFP kit.

## Vehicle compatibility

Operators must be aware that fitting a LFP to either a fifth wheel or a trailer may restrict the vehicles' compatibility with other vehicles.

Incompatibility may arise due to kingpin engagement issues or due to both vehicles being fitted with LFPs. Where both vehicles are fitted with LFP's, there is a likelihood that the surfaces could bind.

## King pin engagement

LFP's attached to either the fifth wheel or the skid plate of a semitrailer can affect the engagement of the kingpin and may require adjustment to the height dimensions of the king pin.

When using a skid plate mounted LFP it is important to check that the overall distance between the skid plate and the end of the kingpin (shown by measurement J in figure 1) meets the minimum dimension requirements of AS/NZS4968.3. At the time of publishing this guide, AS/NZS4968 required a "J" dimension of 84.0mm (+0, -1.5mm) for 50mm and 75mm kingpins and 74.0mm (+0, -2.0mm) for 90mm kingpins.

Where a LFP is fitted to the fifth wheel, it is important to account for the thickness of the LFP with regard to the installation of the king pin required to correctly and safely engage.

Where the kingpin is re-positioned, the kingpin and its mounting must continue to comply with the relevant standards (ADR 62/..) and ensure any modifications are:

- in accordance with the kingpin manufacturer's specifications and installation instructions; and
- carried out and certified in accordance with VSB6 Modification Code P2.

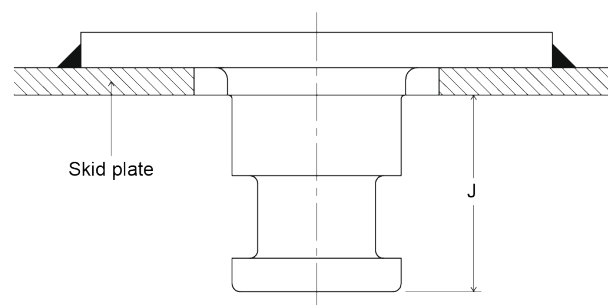

Figure 1: Kingpin height

## Information for manufacturers

The manufacturer of an LFP has the primary obligation to ensure that their product, when installed to a fifth wheel coupling or trailer skid plate, will not result in the coupling becoming defective or unsafe.

The following outlines the standards that must be considered by the LFP manufacturer, the methods - acceptable to the NHVR - by which continued compliance can be demonstrated, and information about how this compliance must be communicated.

## Compliance requirements

Tow couplings are safety critical components that are subject to extensive design and testing to ensure compliance with the strength and reliability requirements of both the applicable ADR62/..

*Mechanical Connections Between Vehicles and Australian and New Zealand Standard AS/NZS 4968 Heavy road vehicles - Mechanical coupling between articulated vehicle combinations.*

Manufacturers of LFPs must validate that where installation of an LFP requires holes to be drilled through the flat upper surface of a fifth wheel, the modified coupling continues to comply with the ADR and AS/NZS4968 requirements. Compliance may be validated as either existing or continued.

## Validation of existing compliance

Where the fifth wheel was designed and constructed to be used with LFPs and the original design has demonstrated compliance with AS/NZS4968, no additional validation is required.

OCM or third party replacement plates may be fitted to the coupling without further certification provided that:

- no modification, such as drilling, to the coupling is required
- the specifications of the LFP are equivalent to those of the OCM LFP
- installation is carried out in accordance with the instructions provided by the OCM manufacturer.

### Validation of continued compliance

Where an AS/NZS4968 compliant fifth wheel is modified to accommodate a non-OCM LFP, the manufacturer of the LFP is required to provide evidence of continued compliance.

Continued compliance may be determined either by engineering assessment or by physical testing carried out at an appropriate testing facility.

Where continued compliance cannot be established by engineering assessment or physical testing, the manufacturer may approach the NHVR for an individual assessment.

**Note:** Once continued compliance has been established, the LFP may be redesigned without revalidation provided the originally assessed bolting arrangement remains unchanged and the original assessment does not prohibit such a change.

### Design requirements

Manufacturers of LFPs are required to consider safety critical areas of the fifth wheel assembly when designing their product and its installation method. These areas include the main structure of the fifth wheel (figure 2) and the area of major load paths (figure 3). Where possible, drilling in these areas should be avoided. If it is necessary that holes be drilled in these areas, additional care, assessment and instruction is required.

#### Main structure of fifth wheel

The fifth wheel assembly is comprised of a flat upper surface that is generally made of cast steel.

The upper surface is supported by the main structure which is a framework of ribs and gussets that provide strength and rigidity to the fifth wheel (The main structure is indicated by red lines in figure 2).

As the main structure provides the necessary support and strength to the fifth wheel drilling bolt holes in the vicinity of the main structure may compromise the overall integrity of the assembly. Where holes are drilled into the main structure or modifications impact on this area, the assembly must be recertified by means of physical testing to AS/NZS4968.

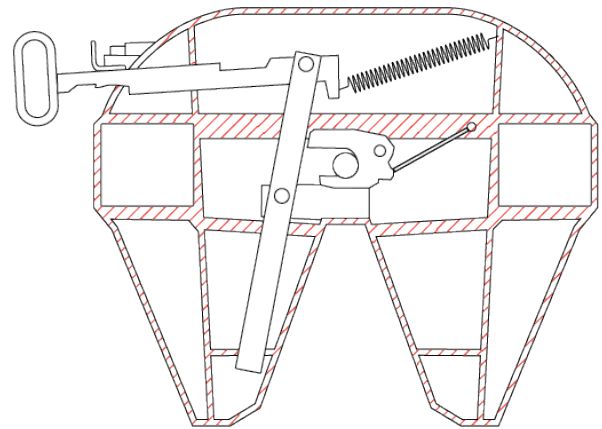

Figure 2: main structure of fifth wheel

#### Major load paths

Bolt holes drilled in or close to the major load paths (see figure 3) are subject to additional stresses during normal use of a fifth wheel coupling. For this reason, it is recommended that drilling bolt holes in this area is avoided.

Where the drilling of bolt holes in the area of a major load path is unavoidable, a detailed stress analysis must be carried out. This analysis must identify the high stress areas located in the major load path and confirm that the bolt hole is not located in areas of high stress.

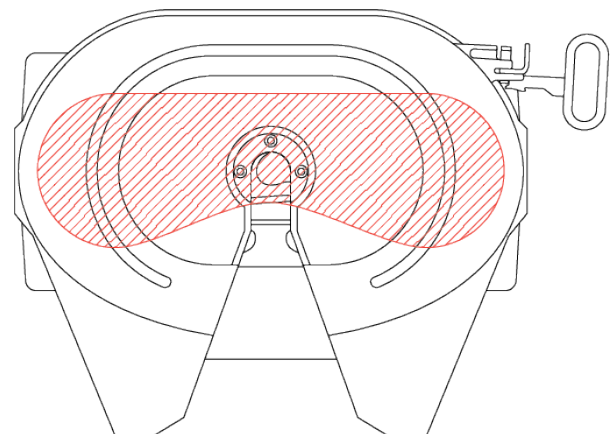

Figure 3: area of major load paths

#### Manufacturer requirements

The LFP manufacturer is required to validate each make/model of fifth wheel/LFP combination offered.

Once the continued compliance of the modified coupling has been established, the manufacturer is required to make certain details of the assessment publicly available and include, at a minimum, the following:

**Required:**

- a declaration of continued compliance stating the method of validation (i.e. by way of engineering assessment or physical testing)
- the make / model of fifth wheel/s the LFP has been validated for
- clear installation instructions for each LFP type and for each tow coupling to which their LFPs can be installed. The installation instructions must:
  - detail how to set up the drilling layout so that holes are correctly located
  - detail any special hole treatment that may be required
  - detail the correct bolting arrangement, including bolt tensions and bolt length
  - outline any safety precautions that may be relevant to ensure that tow coupling operation is not compromised
  - outline any quality and compatibility checks that may be require before installation or during the in-service life of the LFP
  - any requirements stated as a result of the validation of continued compliance
  - be provided with each installation kit supplied
  - be published on the manufacturer’s website for public access

In addition to the above, the LFP manufacturer must ensure all reports and certificates are retained and available to any heavy vehicle regulator on request.

**Continued compliance: Engineering assessment**

To establish continued compliance by way of engineering assessment, the LFP manufacturer must engage the services of a professionally registered engineer expert in fifth wheel or skid plate assessment (whichever is appropriate). The engineer is required to assess the modified coupling against ADR 62/.. and AS/NZS4968.

An engineering assessment may be used to validate continued compliance provided the following conditions are met:

**Permitted**

- drilling of bolt holes through the flat upper surface of the fifth wheel or machining of shallow nut recesses on the underside that remove surface roughness to permit correct nut seating where detailed analysis of the stresses in the area has shown that no fatigue crack/s will arise as a result of the drillings
- the redesign or replacement of LFPs that does not require modification of the tow coupling

**Not permitted**

- drilling of bolt holes through the upper bearing surface of the fifth wheel without sufficient clearance to avoid impacting the main structures
- drilling of bolt holes in or close to the major load paths without detailed stress analysis (see figure 2)
- machining, recessing or other modification - other than shallow recesses to permit correct nut seating of the flat upper surface of the fifth wheel.

Where the engineer identifies a concern or non-compliance, or any of the design features that are on the not permitted items listed, the modified coupling can only be validated by physical testing or individual assessment.

**Engineering report requirements**

A comprehensive formal engineering report must be prepared containing the results of the engineering assessment and be made available to any relevant heavy vehicle regulator on request.

**At a minimum, the report must include:**

**Required:**

- details of the manufacturer for whom the assessment was performed
- details of the LFP and the makes and models of fifth wheel that have been assessed and are covered by the report
- location of the major load path/s and a determination on where it is safe to drill mounting holes for each make and model of fifth wheel covered by the report
- specific bolting layout that is permitted for each make and model of fifth wheel covered by the report
- details of assessment to ensure full engagement between the jaws of the fifth wheel and matching kingpin per section 11.2 of AS/NZS 4968
- any other conditions or requirements that the engineer deems necessary to ensure that the LFPs are correctly and safely installed

**Continued compliance: Physical testing**

In the event that continued compliance cannot be determined by conducting an engineering assessment, the LFP manufacturer may engage an appropriate testing facility to physically test the modified coupling to the requirements of AS/NZS 4968.

A comprehensive formal engineering report must be prepared containing the results of the physical testing

and be made available to any relevant heavy vehicle regulator on request.

**At a minimum, the report must include:**

**Required:**

- details of the manufacturer for whom the assessment was performed
- details of the LFP and the makes and models of fifth wheel that have been assessed, tested and are covered by the report
- specific bolting layout that is permitted for each make and model of fifth wheel covered by the report
- details of the testing undertaken, including the test results and the details of the facility and entity that conducted the testing
- details of assessment to ensure full engagement between the jaws of the fifth wheel and matching kingpin per section 11.2 of AS/NZS 4968
- any other conditions or requirements that the engineer deems necessary to ensure that the LFPs are correctly and safely installed

**Continued compliance: Individual assessment**

Where the installation of an LFP to a tow coupling is not supported by either engineering assessment or physical testing, the manufacturer may approach the NHVR for an individual assessment.

Where the installation of an LFP requires machining, recessing or other modification, other than shallow recesses to permit correct nut seating, an individual assessment will be required.

Individual modification approvals are carried out in accordance with section 87 of the *Heavy Vehicle National Law*.

**Note:** Modification applications must be supported by sound engineering evaluation and only apply to the individual vehicles with VINs identified in the application. Approval is not guaranteed.

**Information for Installers**

Both OCM and third party manufacturers are required to develop detailed installation instructions that must be provided with each LFP. These instructions are integral to ensuring compliance with the relevant standards is achieved and all installations must be done in accordance with the manufacturer’s instructions.

In all cases it is the modifier’s responsibility to show that the modification has been correctly performed and that heavy vehicle safety will not be compromised. The operator of the vehicle must also take steps to ensure the requirements of this VSG have been followed.

Where continued compliance has been established via an individual assessment, the installation instructions will be custom instructions developed for that individual modification.

Any deviation from either the LFP manufacturer’s instructions or the unique installation instructions for a LFP that has been individually assessed is considered a modification that will require individual assessment by NHVR.

**Chain of Responsibility**

The primary duty requires [Chain of Responsibility](#) parties to ensure, so far as is reasonably practicable, that they carry out their transport activities in a way that ensures public safety when heavy vehicles are used on a road.

Keeping up to date with vehicle standards and implementing them in your fleet is one part of your transport activities.

**Complying with the Heavy Vehicle National Law**

The operator of a heavy vehicle must ensure their vehicle complies with the *Australian Design Rules* (ADRs) and the National Regulation. Using or permitting another person to use a defective heavy vehicle on a road is an offence.

A defective heavy vehicle is a vehicle that:

- does not comply with the heavy vehicle safety standards; or
- has a part that does not perform its intended function; or
- has deteriorated to an extent that it cannot be reasonably relied on to perform its intended function.

Penalties can include on-the-spot fines or prosecution. Formal warnings or a defect notice may also be issued. More information can be found at [Heavy vehicle defects - https://www.nhvr.gov.au/hv-defects](https://www.nhvr.gov.au/hv-defects).

**For more information:**

- Visit: [www.nhvr.gov.au/vehiclestandards](http://www.nhvr.gov.au/vehiclestandards)
- Subscribe: [www.nhvr.gov.au/subscribe](http://www.nhvr.gov.au/subscribe)
- Email: [vehiclestandards@nhvr.gov.au](mailto:vehiclestandards@nhvr.gov.au)
- Phone: 13 NHVR (13 64 87)\*

\*Standard 13 call charges apply. Please check with your phone provider.  
© Copyright National Heavy Vehicle Regulator 2024, [creativecommons.org/licenses/by-sa/3.0/au](https://creativecommons.org/licenses/by-sa/3.0/au)  
Disclaimer: This information is only a guide and should not be relied upon as legal advice.

VSG18 Revision history		
First Published	December 2017	
Revised	November 2019	Minor edit
Revised	December 2024	Minor edit