



HEAVY VEHICLE NATIONAL LAW

NEW SOUTH WALES CLASS 1 HEAVY VEHICLE GRAIN AUGER COMBINATION EXEMPTION NOTICE 2015 (No.1)

1. Purpose

The purpose of this Notice is to exempt grain auger combinations from the dimensions in the *Heavy Vehicle (Mass, Dimension and Loading) National Regulation*, subject to the conditions and requirements set out in this Notice.

Note- This Notice replaces the *New South Wales Class 1 Grain Auger Combination Exemption Notice 2010*, previously in force to 30 September 2015.

2. Authorising Provision

This Notice is made under section 117 of the Heavy Vehicle National Law (HVNL).

3. Title

This Notice may be cited as the *New South Wales Class 1 Heavy Vehicle Grain Auger Combination Exemption Notice 2015*.

4. Commencement

This Notice commences on 1 October 2015.

5. Expiry

This Notice expires on 30 September 2020.

6. Definitions

Unless otherwise stated, words and expressions used in this Notice have the same meaning as those defined in the HVNL.

7. Application

- (1) This Notice applies to a grain auger trailer in combination with a towing motor vehicle.
- (2) This Notice applies in New South Wales.

8. Exemption from Prescribed Vehicle Standards

(1) A grain auger combination described in Section 7 of this Notice is exempt from the following provisions of Schedule 6, Part 2 of the Heavy Vehicle (Mass, Dimension and Loading) National Regulation, subject to the conditions in this Notice:

- (a) section 3(1)(a);
- (b) section 5 (1) & (2);
- (c) section 6(3); and
- (d) section 7.

PART 3- CONDITIONS

9. Travel Conditions

(1) Combinations operating under this Notice may operate in the NSW Urban, NSW Eastern and NSW Western zones as defined in the *New South Wales Class 1 Agricultural Vehicles (Notice) 2015*, subject to:

- (a) The dimension limits applicable to each zone as set out in Section 10(1) of this Notice;
- (b) The pilot vehicle requirements as set out in Part 4 of this Notice; and
- (c) The travel restrictions imposed as set out in Appendix 2 of the *New South Wales Class 1 Agricultural Vehicles (Notice) 2015*.

10. Special Conditions

(1) A vehicle operating under this Notice must not exceed the dimension limits set out in Table 1, subject to Section 10(2) of this Notice.

Zone	A	B	C	D	E	F
NSW Urban Zone	(up to) 7.0 m	(up to) 19.0 m	(up to) 23.0 m	(up to) 4.3 m	(up to) 0.5 m	(up to) 3.0 m
NSW Eastern Zone	(up to) 9.0 m	(up to) 19.0 m	(up to) 25.0 m	(up to) 4.3 m	(up to) 0.5 m	(up to) 3.5 m
NSW Western Zone	(up to) 10.0 m	(up to) 19.0 m	(up to) 25.0 m	(up to) 4.3 m	(up to) 0.5 m	(up to) 3.5 m

(2) The auger's rear overhang (Dimension A) must be the lesser of:

- (a) The dimension limit set out in Table 1; and
- (b) 53% of the auger's overall length (Dimension B in diagram 1)

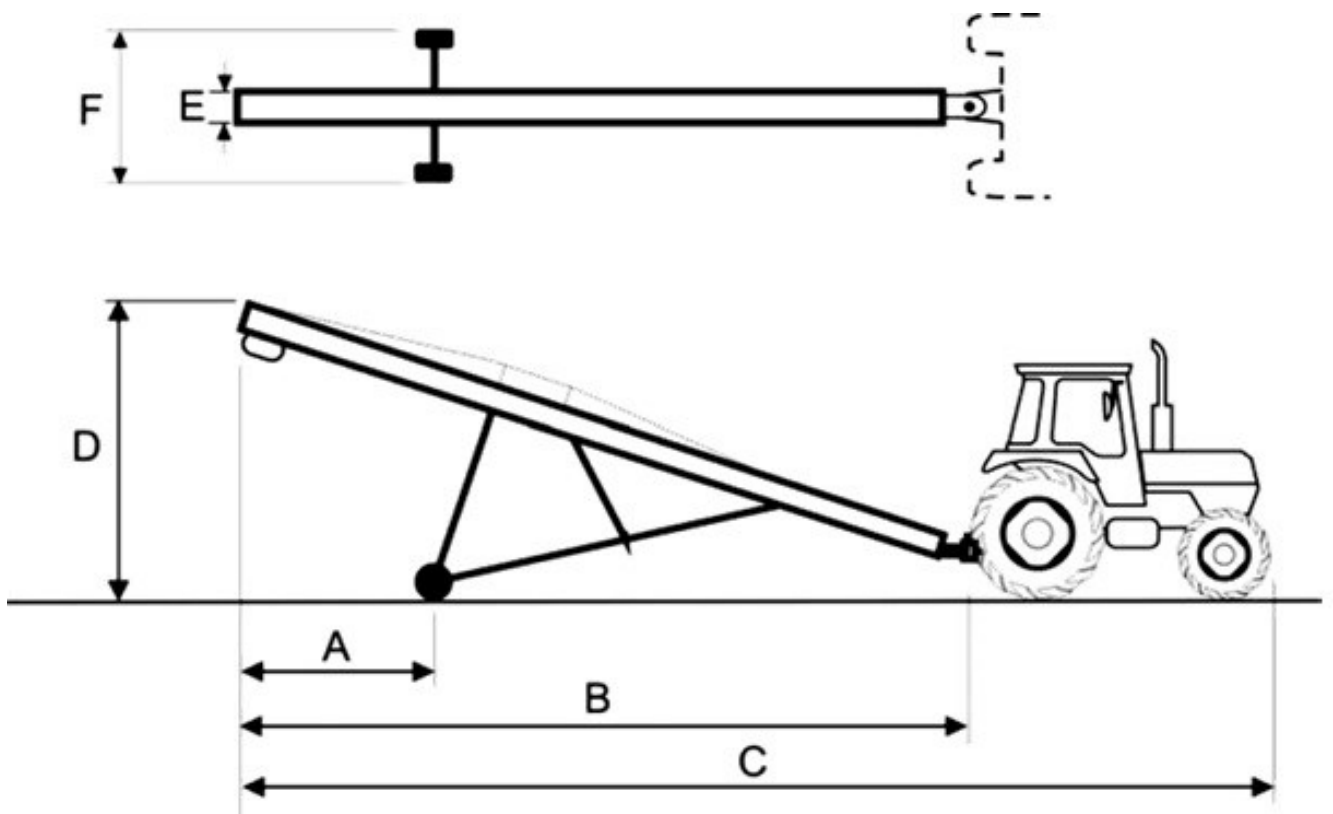

Diagram 1 Grain Auger Dimensions

- A** means the rear overhang of the grain auger as defined in Schedule 6 of the *Heavy Vehicle (Mass, Dimension and Loading) National Regulation*
- B** means the length of the grain auger
- C** means the overall length of the grain auger in combination with the towing motor vehicle
- D** means the height of the grain auger
- E** means the width of the grain auger's tube
- F** means the maximum width of the combination

PART 4 – ZONAL PILOT VEHICLE REQUIREMENTS

11. Pilot Vehicle Requirements

- (1) When a combination, to which this Notice applies, is operating in the NSW Urban Zone and the distance of dimension A exceeds 5.5m, it must be accompanied by at least one pilot vehicle.
- (2) A combination operating under this Notice in the NSW Eastern Zone must be accompanied by at least one pilot vehicle if:
 - (a) The distance of Dimension A exceeds 7.0m; or
 - (b) The distance of Dimension F exceeds 3.0m.
- (3) A combination operating under this Notice in the NSW Western Zone must be accompanied by at least one pilot vehicle if the distance of Dimension A exceeds 9.0m.

Dated 25 September 2015

A handwritten signature in black ink, appearing to read 'Geoff Casey', is positioned above the printed name and title.

Geoff Casey
Acting Chief Executive Officer
National Heavy Vehicle Regulator