

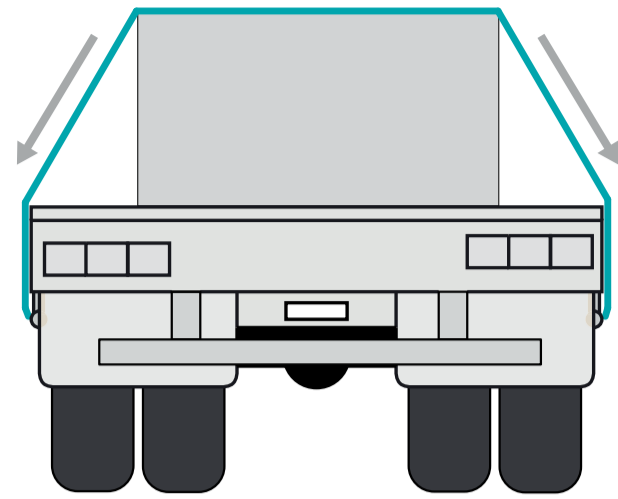

Pre-tension is the amount of clamping force a tensioner can apply to the load and is provided by the chain or webbing tensioner mechanism. Some useful tips are:

- ✓ Different devices have different pre-tension
- ✓ Pre-tension is not the same as lashing capacity
- ✓ Select the correct LRG table based on pre-tension
- ✓ Poor clamping = poor pre-tension



⚠ RISKS

⚠ USING NON-RATED EQUIPMENT

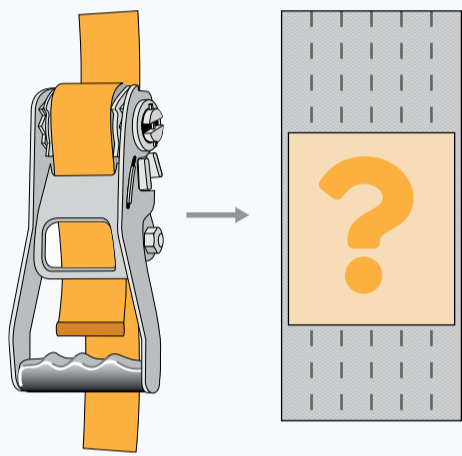

⚠ GUESSING PRE-TENSION REQUIRED

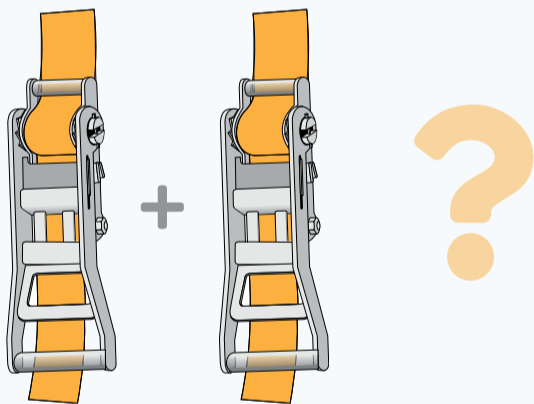

⚠ EXCESSIVE WRAPS AROUND SPOOL

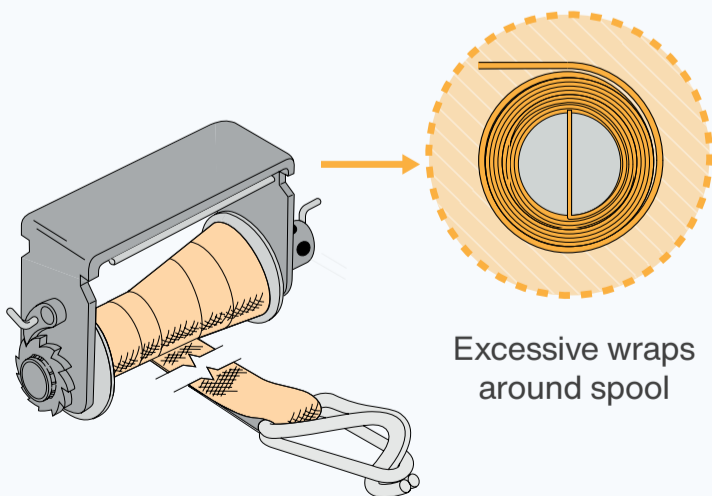

✓ GOOD PRACTICE

✓ USING RATED EQUIPMENT

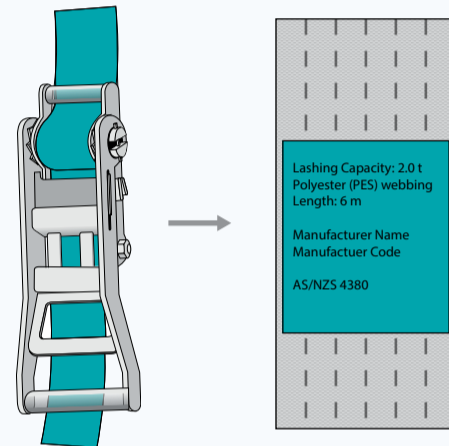

✓ CALCULATING PRE-TENSION REQUIRED

Load Restraint Guide 2018

APPENDICES		NUMBER OF TIE-DOWN LASHINGS	
		FOR TRUCKS AND TRAILERS	
		UNLOCKED (EXCEPT TO 4.5t)	
Category	Sub-category	Number of lashings	Number of lashings
Trucks	Trucks	4	4
	Trailers	4	4
Trailers	Trailers	4	4
	Trucks	4	4

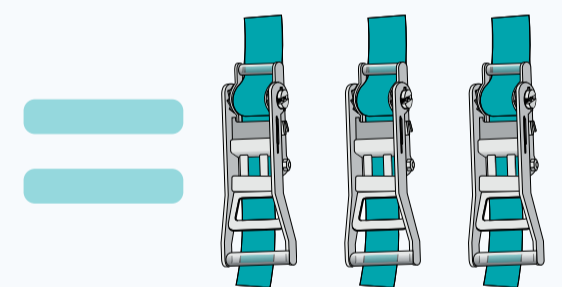

✓ MINIMUM ONE AND A HALF WRAPS

